

ESTUN



ProNet Plus

All Digital AC Servo Systems





Corporate Information

As a national top AC servo system research, development and production base, Estun Automation is devoted to R&D, manufacturing and sales of high-end products in the realm of motion control. We are holding completely self-owned IPR technology of our AC servo systems which can be applied in CNC machine, textile machine, packing machine, printing machine, electronics manufacturing equipment, industrial robot, manipulator, wood-working machine, robotization production line, electro-hydraulic hybrid-driven and fully electrical injection moulding machine, etc. Now, Estun has established long-term strategic partnership with many prestigious machine manufacturers and becomes their first cooperation option for motion control products in both domestic and international market.

Service Network

Hotline

400-025-3336



First-class service guarantee

- Headquartered in Nanjing with rich experience in product design and manufacturing process control, possessing a first-class modern production base
- Offices in Guangdong, Guangxi, Fujian, Jiangxi, Hu'nan, Hubei, Chongqing, Gansu, Shanxi, He'nan, Anhui, Zhejiang, Jiangsu, Shandong, Tianjing and Liaoning
- 38 nationwide warranty stations and 2 international repair centers in Poland and USA
- More than 130 authorized domestic and international agencies and system integrators

Professional sales and service teams offer a quick response to customers' needs.

Platform Strength

As a manufacturer of AC servo systems and motion control systems, Estun Automation Technology Co., Ltd. owns advanced R&D platform and testing equipment. The platform and equipment have offered solid foundation for further technological research and development in AC servo products and motion control systems and it created a good environment to build a high level R&D team. As one of the few domestic manufactures with above mentioned R&D capabilities and testing equipments, Estun becomes the most competitive company in the field of AC servo system and motion control total solutions.

Technological R&D



RMxpert Finite element analysis software Maxwell 2D/3D, (ANSYS company, USA)

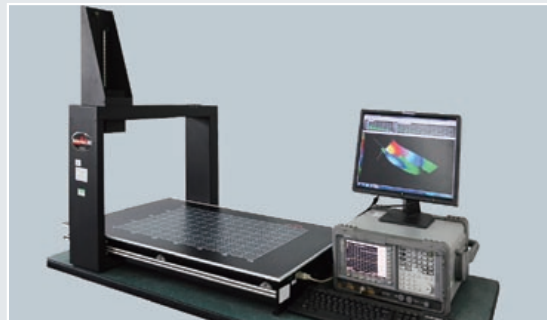

Whole set of EMI scanner (Detectus AB company, Sweden) & Anti-interference developing system (Agilent company, USA)



The world's most advanced servo drive and motor testing system and analysis software (MAGTROL company, Switzerland)



The latest multi-function and high precision electric power analyzer for AC servo system (Newtons4th Ltd,UK; YOKOGAWA, Japan)

Production Equipment



SMT Production Line



Servo Drive Assembling Line



Servo Motor Production Line



Servo Motor Testing System



Automatic Laser Welding



Automatic Wiring

General Introduction

ProNet Series AC Servo System

Features

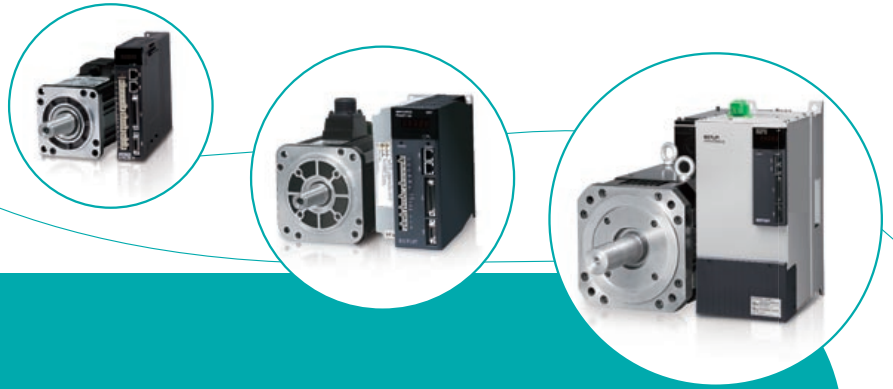

- Various models, wide power range : 50W~5kW
- Multiple feedback options : 17bits / 20bits serials encoder
- Power supply: single phase/three phase 200VAC, three phase 400VAC
- Various communication options: Modbus, CANopen, EtherCAT
- Frequency response 1.6kHz
- Current feed-forward and acceleration feed-forward function
- Online real time load inertia inspecting and auto-tuning function
- Low frequency vibration suppression function
- High performance under low rigid environment
- Dynamic electronic gear ratio switching function
- Homing function available under position control mode
- UL certified and CE certified

Typical Application

- Machine tools (Metal forming, CNC router, Laser cutting, Water jet, Wood processing)
- Textile machine (Warping machine, Warp knitting machine, Rapier loom, Air jet, Water jet machine, Quilter machine, Dyeing machine)
- Packing machine (Vertical packing machine, Pillow packing machine, Sealing packing machine, Liquid packing machine)
- Printing machine (Photogravure press, Lithographic press, Relief printing machine)
- Electronics manufacturing equipment (Sorting machine, Chip moulder, Winding machine, Die-cutting machine, Lithium battery production line, Non-standard automatic production line)
- Industrial robot, manipulator
- Hybrid, Die-casting machine, Injection molding machine, Plastic extruding machine



ProNet Series

- Various voltage input: 200V, 400V
- Power supply: 50W~5kW
- 17 /20 bit Serial encoder
- Standard: CANopen
Options: EtherCAT
- Used in high precision automation, high speed bus communication

Model Comparison Table

Motor Series	Voltage	Power (kW)	Servo Motor	Servo Drive	Encoder Cable	Power Cable	Brake Cable
EMJ 3000r/min	Single-phase 200VAC	0.05	EMJ-A5ASA2□	PRONET-A5AMG PRONET-A5AEG-EC	PSP-JB24-XX(Incremental) PDP-JB24-XX(Absolute)	PDM-JB18-XX (Without brake) PDMB-JB18-XX (With brake)	(Built in power cable)
			EMJ-01ASA2□	PRONET-01AMG PRONET-01AEG-EC			
		0.2	EMJ-02ASA2□	PRONET-02AMG PRONET-02AEG-EC	PDP-JE24-XX PBP-JE24-XX		
			EMJ-02AFA2□				
		0.4	EMJ-04ASA2□	PRONET-04AMG PRONET-04AEG-EC	PDP-JE24-XX PBP-JE24-XX		
			EMJ-04AFB2□				
	Three-phase 200VAC	0.75	EMJ-08ASB2□	PRONET-08AMG PRONET-08AEG-EC	PDP-JE24-XX PBP-JE24-XX		
			EMJ-08AFB2□				
		1	EMJ-10ASB2□	PRONET-10AMG PRONET-10AEG-EC	PDP-JE24-XX PBP-JE24-XX		
			EMJ-10AFB2□				
		1	EMG-10ASB2□	PRONET-10AMG PRONET-10AEG-EC	PDP-GA24-XX- II PSP-GA24-XX- II		
			EMG-10AFB2□				
EMG 2000r/min	Three-phase 200VAC	1.5	EMG-15ASB2□	PRONET-15AMG PRONET-15AEG-EC	PDP-GA24-XX- II PSP-GA24-XX- II	PDM-GA14-XX- II (Without brake) PDMB-GA14-XX- II (With brake)	(Built in power cable)
			EMG-15AFB2□				
		2	EMG-20ASB2□	PRONET-20AMG PRONET-20AEG-EC	PDP-GA24-XX- II PSP-GA24-XX- II		
			EMG-20AFB2□				
		3	EMG-30ASA2□	PRONET-30AMG PRONET-30AEG-EC	PDP-GA24-XX PSP-GA24-XX		
			EMG-30AFA2□				
EMG 2000r/min	Three-phase 400VAC	5	EMG-50ASA2□	PRONET-50AMG PRONET-50AEG-EC	PDP-GA24-XX PSP-GA24-XX	PDM-GD12-XX	Only equipped with plug HMS3106A10SL-3S (SHENYANGXINGHUA) [With cable clamp]
			EMG-50AFA2□				
		1	EMG-10DSB2□	PRONET-10DMG PRONET-10DEG-EC	PDP-GA24-XX- II PSP-GA24-XX- II		
			EMG-10DFB2□				
		1.5	EMG-15DSB2□	PRONET-15DMG PRONET-15DEG-EC	PDP-GA24-XX- II PSP-GA24-XX- II		
			EMG-15DFB2□				
2	EMG-20DSB2□	PRONET-20DMG PRONET-20DEG-EC	PDP-GA24-XX- II PSP-GA24-XX- II				
	EMG-20DFB2□						
3	EMG-30DSA2□	PRONET-30DMG PRONET-30DEG-EC	PDP-GA24-XX PSP-GA24-XX				
	EMG-30DFA2□						
5	EMG-50DSA2□	PRONET-50DMG PRONET-50DEG-EC	PDP-GA24-XX PSP-GA24-XX				
	EMG-50DFA2□						

Motor Series	Voltage	Power (kW)	Servo Motor	Servo Drive	Encoder Cable	Power Cable	Brake Cable
EML 1000r/min	Three-phase 200VAC	1	EML-10ASB2□	PRONET-10AMG PRONET-10AEG-EC	PDP-GA24-XX-II	PDM-GA14-XX-II (Without brake)	(Built in power cable)
			EML-10AFB2□		PSP-GA24-XX-II	PDMB-GA14-XX-II (With brake)	
		2	EML-20ASA2□	PRONET-20AMG PRONET-20AEG-EC	PDP-GA24-XX	PDM-GD12-XX	Only equipped with plug HMS3106A10SL-3S (SHENYANGXINGHUA) [With cable clamp]
			EML-20AFA2□		PSP-GA24-XX		
		3	EML-30ASA2□	PRONET-30AMG PRONET-30AEG-EC	PDP-GA24-XX		
			EML-30AFA2□		PSP-GA24-XX		
	4	EML-40ASA2□	PRONET-50AMG PRONET-50AEG-EC	PDP-GA24-XX			
		EML-40AFA2□		PSP-GA24-XX			
	Three-phase 400VAC	1	EML-10DSB2□	PRONET-10DMG PRONET-10DEG-EC	PDP-GA24-XX-II	PDM-GA14-XX-II (Without brake)	(Built in power cable)
			EML-10DFB2□		PSP-GA24-XX-II	PDMB-GA14-XX-II (With brake)	
		2	EML-20DSA2□	PRONET-20DMG PRONET-20DEG-EC	PDP-GA24-XX	PDM-GD12-XX	Only equipped with plug HMS3106A10SL-3S (SHENYANGXINGHUA) [With cable clamp]
			EML-20DFA2□		PSP-GA24-XX		
3		EML-30DSA2□	PRONET-30DMG PRONET-30DEG-EC	PDP-GA24-XX			
		EML-30DFA2□		PSP-GA24-XX			
4	EML-40DSA2□	PRONET-50DMG PRONET-50DEG-EC	PDP-GA24-XX				
	EML-40DFA2□		PSP-GA24-XX				

- Notes: ① Single-turn absolute servo motor can be used as incremental servo motor(do not use multi-turn information). The encoder cable do not need battery.
- ② -XX means encoder cable length. Optional 1.5m, 3m, 5m, 8m, 10m, 12m, 15m, 20m length or customized to meet your need.

Servo Drive Specification

Specification Description

ProNet – 10

ProNet Servo Drive

A

Rated Power

E

Power Voltage

G – EC

Encoder Interface

Bus Style

Sign	Spec.	Sign	Spec.	Sign	Spec.	Sign	Spec.	Sign	Spec.
A5	0.05kW	A	200VAC	M	Pulse Analog	G	17 Bit/20 Bit	-EC	EtherCAT
01	0.1kW	D	400VAC		CANopen		Serial Encoder		Bus
02	0.2kW				Control		(Automatic	None	M Control
04	0.4kW			E	Support		Identification)		Style
08	0.75kW				Extended Bus				
10	1.0kW				Function				
15	1.5kW								
20	2.0kW								
30	3.0kW								
50	5.0kW								

Note : ProNet-□□□□G can identify automatically 20 bit incremental motor and 17 bit absolute motor.



Ratings

Servo Drive Model	ProNet-	A5A	01A	02A	04A	08A	10A	10D	15A	15D	20A	20D	30A	30D	50A	50D
Applicable Servo Motors Model	EMJ-	A5A	01A	02A	04A	08A	10A	-	-	-	-	-	-	-	-	-
	EMG-	-	-	-	-	-	10A	10D	15A	15D	20A	20D	30A	30D	50A	50D
	EML-	-	-	-	-	-	10A	10D	-	-	20A	20D	30A	30D	40A	40D
Continuous Output Current(Arms)		1.0	1.1	1.4	2.8	4.0	6.0	3.2	9.0	5.0	12.0	6.4	18.0	9.0	28.0	15.0
Max. Output Current(Arms)		3.0	3.3	4.2	8.4	12.0	18.0	9.6	28.0	15.0	42.0	19.2	46.0	27.0	64.0	45.0
Main Input Power Supply Capacity(kVA)		0.2	0.3	0.5	0.9	1.3	1.8	1.8	2.5	2.8	3.5	3.5	4.5	5.0	7.5	8.2
DC24V Power Supply Capacity(W)		-	-	-	-	-	-	30.0	-	30.0	-	30.0	-	45.0	-	45.0

Specification

Items			Specification
Input Power Supply	Main Circuit	200V	Single-phase 200 to 230VAC 50/60Hz (0.05kW-0.4kW) Three-phase 200 to 230VAC 50/60Hz (0.75kW-5.0kW)
		400V	Three-phase 380 to 440VAC 50/60Hz (1.0kW-5.0kW)
	Control Circuit	200V	Single-phase 200 to 230VAC 50/60Hz (0.05kW-5.0kW)
		400V	24VDC (1.0kW-5.0kW)
Control Method			SVPWM Control
Feedback			17 Bits Absolute Encoder: 131072P/R 20 Bits Incremental Encoder: 1048576P/R
Operating Conditions	Ambient / Storage Temperature		Ambient Temperature: 0 to +55°C, Storage Temperature: -25 to+85°C
	Ambient / Storage Humidity		5%~95% (no condensation)
	Elevation		1000m or less
	Vibration / Impact Resistance		Vibration Resistance: 4.9m/s ² , Impact Resistance: 19.6m/s ²
Configuration			Base-mounted
Performance	Speed Control Range		1:5000
	Speed Regulation	Load Regulation	0 to 100% load: ±0.01% max. (at rated speed)
		Voltage Regulation	Rated voltage, ±10%: 0% (at rated speed)
		Temperature Regulation	25±25°C: ±0.1% max. (at rated speed)
Torque Control	Analog Input	Reference Voltage	±10VDC at rated torque (variable setting range: ±0 to 10VDC) Max. input voltage: ±12V
		Input Impedance	About 10MΩ min.
		Circuit Time Constant	10μs

Items		Specification	
Speed Control	Analog Input	Reference Voltage	±10VDC at rated torque (variable setting range: ±0 to 10VDC) Max. input voltage: ±12V
		Input Impedance	About 10MΩ min.
		Circuit Time Constant	10μs
	Set Speed Reference	Speed Selection	Speed 1 to 7 selection
	Function	Soft Start Setting	0 to 10s (can be set individually for acceleration and deceleration)
Position Control	Reference Pulse	Type	Sign+pulse train, CCW+CW pulse train, or 90° phase difference 2-phase pulse (phase A + phase B)
		Form	Non-insulated line driver (+5V level), open collector
		Frequency	x1 multiplier: 4Mpps x2 multiplier: 2Mpps x4 multiplier: 1Mpps Open collector: 200kpps Frequencies drop when the dutues have errors
	Set Position Reference	Position Setting	Can set 16 position reference
I/O Signals	Encoder Output Pulse		Phase A, phaseB, phase C: line driver output The number of dividing pulse: Any setting ratio is available
	Sequence Input	Number of Channels	8 channels
		Function	Signal allocations and positive/negative logics can be modified: Servo ON (/S-ON), P control (/P-CON), alarm reset (/ALM-RST), clear error pulse (/CLR), forward run prohibited (P-OT), reverse run prohibited (N-OT), forward torque limit (/P-CL), reverse torque limit (/N-CL)
	Sequence Output	Number of Channels	4 channels
		Function	Servo alarm (ALM) Signal allocations and positive/negative logics can be modified: Positioning completion (/COIN), speed agree detection (/V-CMP), motor rotation detection (/TGON), servo ready (/S-RDY), torque limit detection (/CLT), brake interlock (/BK), encoder C pulse (/PGC), over travel signal (/OT)
Others	Regenerative Processing Functions		0.75kW~5kW: Built-in regenerative resistor; 0.05kW~0.4kW: External regenerative resistor
	Protective Functions		Overcurrent, overvoltage, low voltage, overload, regeneration error, overspeed, etc.
	Utility Functions		Alarm trace back, JOG operation, Inertia detections, etc.
	Display Functions		CHARGE (red), POWER (green), 7-segment LEDx5 (Built-in digital operator function)
	Communications		RS-485 communication port, MODBUS protocol ; CAN communication port, CANopen protocol; EtherCAT communication module, CiA402 protocol;

Communication

Modbus

Modbus

ProNet series servo drives provide the Modbus communication function with RS-485 interface, which can be used to easily set parameters or to perform monitoring operations and so on.

Items	Specifications
Communication standard	Modbus
Physical layer	RS-485 transmission
Bus connection	CN3 (RJ45): Signal IN CN4(RJ45): Signal OUT
Cable	Twisted pair cable
Baud rate	4800bps, 9600bps, 19200bps
Communication Mode	ASCII, RTU

EtherCAT



- Integrated EtherCAT Module
- High communication speed
- Precise multiple axis synchronous control
- Revolution of traditional field bus control

Items	Specifications
Communication standard	IEC 61158 Type12, IEC 61800-7 CiA402 Drive Profile
Physical layer	100BASE-TX (IEEE802.3)
Bus connection	CN4 (RJ45): EtherCAT Signal IN CN5 (RJ45): EtherCAT Signal OUT
Cable	Class-5 twisted pair cable
Communication distance	Nod space: within 100 meters
SyncManager	SM0: output mailbox, SM1: input mailbox SM2: output proces data, SM3: input process data
FMMU	FMMU0: mapping to process data (RxPDO) Receiving area FMMU1: mapping to process data (TxPDO) Transmitting area FMMU2: mapping to mailbox status
EtherCAT Commands (Data Link Layer)	APRD, FPRD, BRD, LRD, APWR, FPWR, BWR, LWR, ARMW, FRMW Note: APRW, FPRW, BRW, LRW Commands are not supported
PDO data	Dynamic PDO mapping
Mailbox (CoE)	Emergency event, SDO request, response, SDO information Note: do not support TxPDO/RxPDO and remote TxPDO/RxPDO
Differential clock (DC)	Free-run, DC mode (set active in confi gur ation) Supported DC period: 250us - 8ms
SII	256 bytes (read - only)
LED Indicator	EtherCAT System indicator (SYS) x1 EtherCAT Run indicator (RUN) x1 EhterCAT Error indicator (ERR) x1
CiA402 Drive Profile	Homing mode, Profile position mode, Profile velocity mode, Profile torque mode, Cyclic synchronous position mode, Cyclic synchronous velocity mode, Cyclic synchronous torque mode, Touch Probe function

CANopen



Standard CAN bus interfaces are available in ProNet series servo drives, which makes it easy to get integrated into a distributed control system.

Items	Specifications
Communication standard	CiA-DS301 CiA402 Drive Profile
Physical layer	ISO 11898-2 CiA 303-1
Bus connection	CN3 (RJ45): Signal IN CN4 (RJ45): Signal OUT
Cable	Twisted pair cable
Baud rate	50Kbps, 100Kbps, 125Kbps, 250Kbps, 500Kbps, 1Mbps
COB	SDO, PDO, SYNC, EMCY, NMT, Heartbeat
Communication mode	Homing mode, speed control mode, position control mode, position interpolation mode
PDO data	Dynamic PDO mapping, 4 sending PDO, 4 receving PDO

Servo Motor Specification

EMJ Model

Specification Description

EMJ - 08 A F B 2 4

EMJ Model
Servo Motor

Rated Output
Power

Power
Voltage

Encoder

Designing
Sequence

Shaft End

Option Parts

Sign	Spec.	Sign	Spec.	Sign	Spec.	Sign	Spec.	Sign	Spec.		
A5	0.05kW	A	200VAC	F	20 Bit Incremental : Encoder 1048576P/R	A, B, H	Designing Sequence	2	Flat, With Keys, With Screw Thread	2	With Oil Seal
01	0.1kW			S	17 Bit Absolute Encoder: 131072P/R					4	With Oil Seal, With Brake (DC24V)
02	0.2kW										
04	0.4kW										
08	0.75kW										
10	1.0kW										

Rated Value and Specification

Voltage		200VAC						
Servo Motor Model	EMJ-	A5ASA□□	01ASA□□	02ASA□□ 02AFA□□	04ASA□□ 04AFB□□	04ASH□□ 04AFH□□	08ASB□□ 08AFB□□	10ASB□□ 10AFB□□
Rated Output Power	kW	0.05	0.1	0.2	0.4		0.75	1.0
Rated Torque	N·m	0.16	0.32	0.64	1.27		2.39	3.18
Instantaneous Peak Torque	N·m	0.48	0.96	1.91	3.82		7.16	9.55
Rated Current	Arms	0.6	1.1	1.4	2.8		4.0	5.3
Instantaneous Max Current	Arms	1.7	3.0	4.2	8.4		12.0	15.9
Rated Speed	r/min	3000						
Max. Speed	r/min	5000			4500			
Rotor Moment of Inertia	×10 ⁻⁴ kg·m ²	0.019 (0.05)	0.035 (0.052)	0.19 (0.23)	0.31 (0.35)	0.7 (0.74)	1.35 (1.47)	1.74 (1.87)
Brake Rated Voltage		DC24V±10%						
Brake Rated Power	W	4			7.2		11.5	
Brake Holding Torque	N·m	0.318			1.3		3.2	
Encoder		17 bit Absolute Encoder 131072 P/R			20 bit Incremental Encoder 1048576P/R 17 bit Absolute Encoder 131072 P/R			
Insulation Class		F						
Ambient Temperature		0 to +40°C (no freezing)						
Ambient Humidity		20% to 80% RH (non-condensing)						
Vibration		49m/s ²						
Enclosure		Totally Enclosed, Self-cooled, IP65 (Except for shaft opening, when not equipped with oil seal; Except for connectors, when not equipped with waterproof connectors.)						

Note: The values in parentheses are for servo motors with holding brakes.

EMG Model

Specification Description

EMG-10 A

EMG Model
Servo Motor

Rated Output
Power

Power
Voltage

F

Encoder

B

Designing
Sequence

2

Shaft End

4

Option Parts

Sign	Spec.	Sign	Spec.	Sign	Spec.	Sign	Spec.	Sign	Spec.	Sign	Spec.
10	1.0kW	A	200VAC	F	20 Bit Incremental : Encoder 1048576P/R	A,B	Designing Sequence	2	Flat, With Keys With Screw Thread	2	With Oil Seal
15	1.5kW	D	400VAC	S	17 Bit Absolute Encoder: 131072P/R			4	With Oil Seal, With Brake (DC24V)		
20	2.0kW										
30	3.0kW										
50	5.0kW										

Rated Value and Specification

Voltage		200VAC / 400VAC										
Servo Motor Model	EMG-	10A□B□□	10D□B□□	15A□B□□	15D□B□□	20A□B□□	20D□B□□	30A□A□□	30D□A□□	50A□A□□	50D□A□□	
Rated Output Power	kW	1.0	1.0	1.5	1.5	2.0	2.0	3.0	3.0	5.0	5.0	
Rated Torque	N·m	4.78	4.78	7.16	7.16	9.55	9.55	14.3	14.3	23.9	23.9	
Instantaneous Peak Torque	N·m	14.3	14.3	21.5	21.5	28.7	28.7	43.0	43.0	71.6	71.6	
Rated Current	Arms	5.8	3.0	8.2	4.3	11.3	5.7	18.0	8.8	28.0	15.0	
Instantaneous Max. Current	Arms	17.4	9.0	24.6	12.9	33.9	17.1	54.0	26.4	84.0	45.0	
Rated Speed	r/min	2000										
Max. Speed	r/min	3000										
Rotor Moment of Inertia	$\times 10^{-4} \text{kg}\cdot\text{m}^2$	13.2(14.3)		18.4(19.5)		23.5(24.6)		41.3 (44.5)		65.7 (68.9)		
Brake Rated Voltage		DC24V \pm 10%										
Brake Rated Power	W	19.5						35				
Brake Holding Torque	N·m	12						40				
Encoder		20 bit Incremental Encoder 1048576P/R 17 bit Absolute Encoder 131072 P/R										
Insulation Class		F										
Ambient Temperature		0 to +40°C (No freezing)										
Ambient Humidity		20% to 80% RH (Non-condensing)										
Vibration		24.5m/s ²										
Enclosure		Totally Enclosed, Self-cooled, IP65 (Except for shaft opening, when not equipped with oil seal.)										

Note: The values in parentheses are for servo motors with holding brakes.

EML Model

Specification Description

EML-10 A

EML Model Servo Motor

Rated Output Power

Power Voltage

F B

Encoder

Designing Sequence

2

Shaft End

4

Option Parts

Sign	Spec.	Sign	Spec.	Sign	Spec.	Sign	Spec.	Sign	Spec.	Sign	Spec.
10	1.0kW	A	200VAC	F	20 Bit Incremental : Encoder 1048576P/R	A,B	Designing Sequence	2	Flat, With Keys With Screw Thread	2	With Oil Seal
20	2.0kW	D	400VAC	S	17 Bit Absolute Encoder: 131072P/R					4	With Oil Seal, With Brake (DC24V)
30	3.0kW										
40	4.0kW										

Rated Value and Specification

Voltage		200VAC / 400VAC							
Servo Motor Model	EML-	10A□B□□	10D□B□□	20A□A□□	20D□A□□	30A□A□□	30D□A□□	40A□A□□	40D□A□□
Rated Output Power	kW	1.0		2.0		3.0		4.0	
Rated Torque	N.m	9.55		19.1		28.7		38.2	
Instantaneous Peak Torque	N.m	28.7		57.3		86.0		114.6	
Rated Current	Arms	5.5	2.8	12.0	6.2	18.0	9.0	24.0	12.2
Instantaneous Max. Current	Arms	16.5	8.4	36.0	18.6	54.0	27.0	72.0	36.6
Rated Speed	r/min	1000							
Max. Speed	r/min	1500							
Rotor Moment of Inertia	×10 ⁻⁴ kg·m ²	23.5(24.6)		53.5 (56.7)		77.8 (81.0)		102.2 (105.4)	
Brake Rated Voltage		DC24V±10%							
Brake Rated Power	W	19.5		35					
Brake Holding Torque	N·m	12		40					
Encoder		20 bit Incremental Encoder 1048576P/R 17 bit Absolute Encoder 131072 P/R							
Insulation Class		F							
Ambient Temperature		0 to + 40°C (No freezing)							
Ambient Humidity		20 to 80% RH (Non-condensing)							
Vibration		24.5m/s ²							
Enclosure		Totally Enclosed, Self-cooled, IP65 (Except for shaft opening, when not equipped with oil seal.)							

Note: The values in parentheses are for servo motors with holding brakes.

Torque-Speed Feature

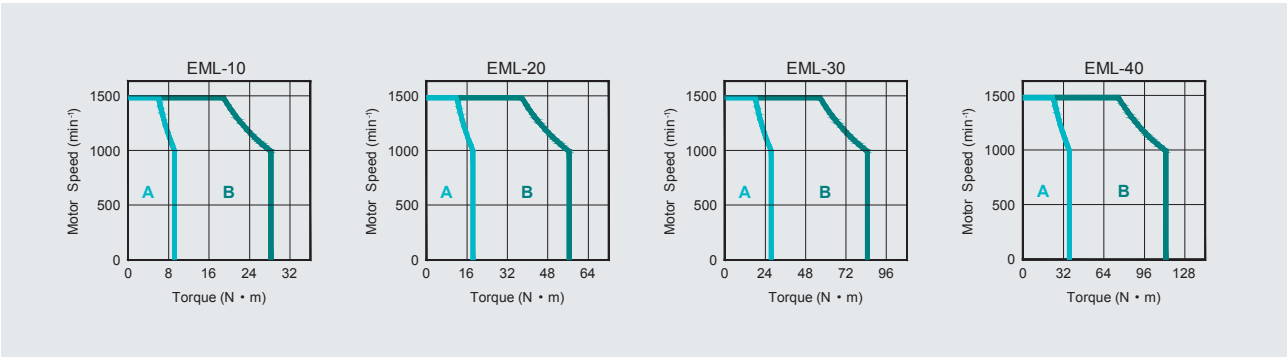
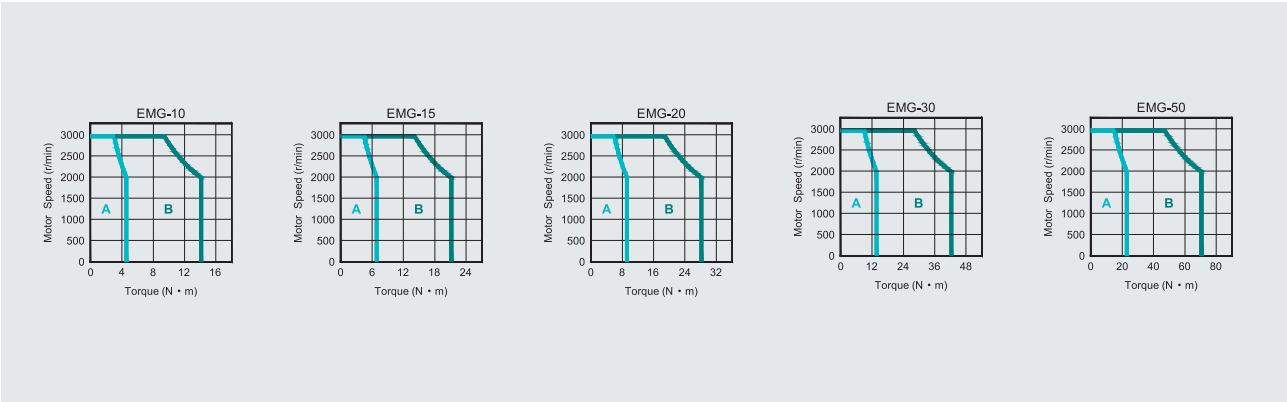
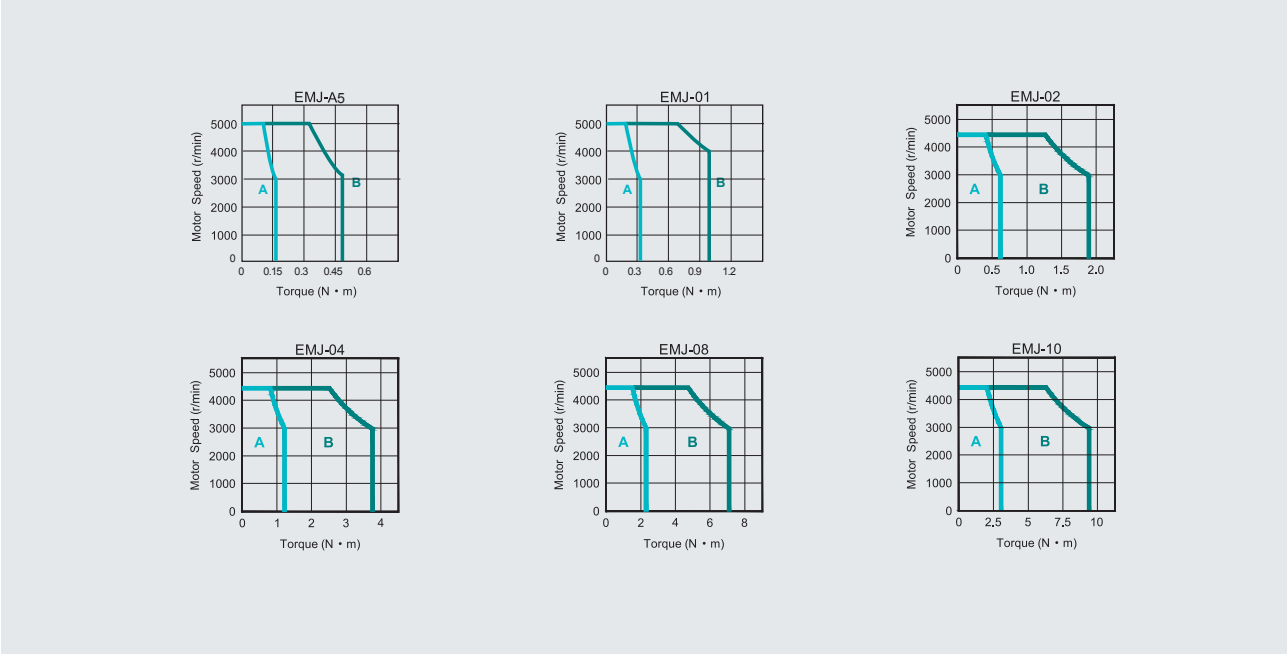

A: Continuous Working Area B: Repeatedly Working Area

Connection

Single-phase 200VAC (ProNet-A5A to 04A) Main Circuit Wiring

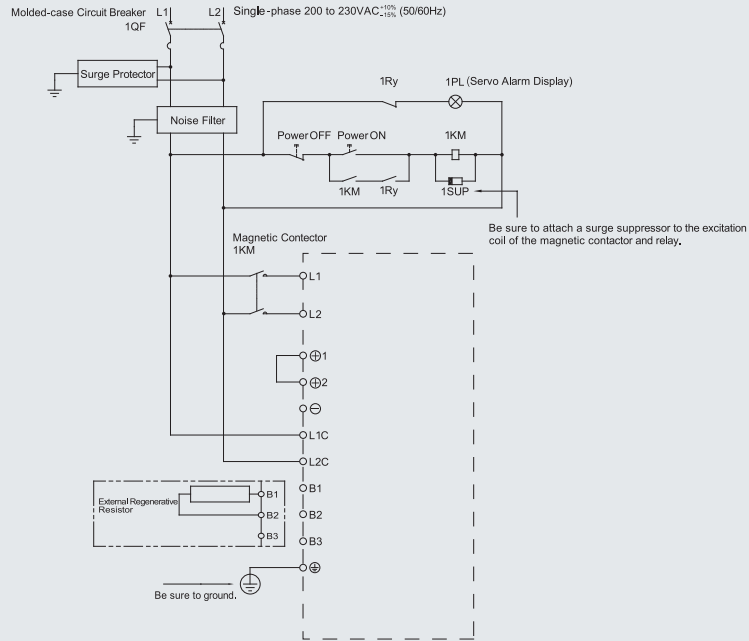

Three-phase 200VAC (ProNet-08A to ProNet-50A) Main Circuit Wiring

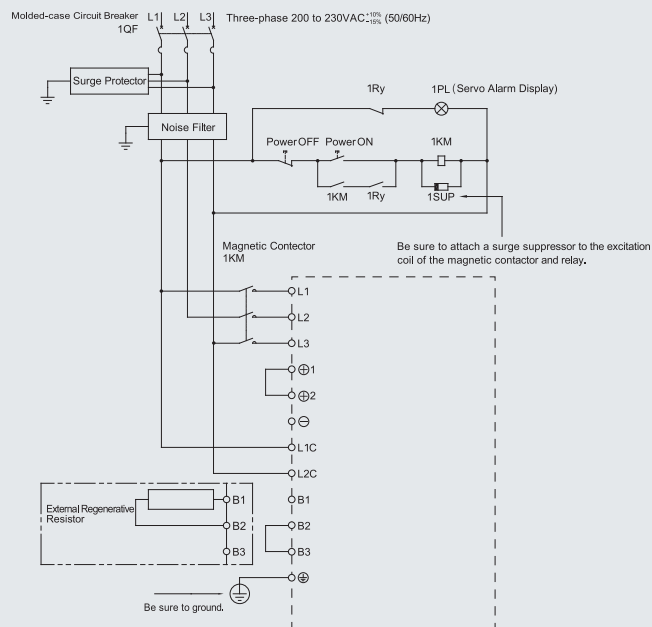

Single-phase 400VAC (ProNet-10D to ProNet-50D) Main Circuit Wiring

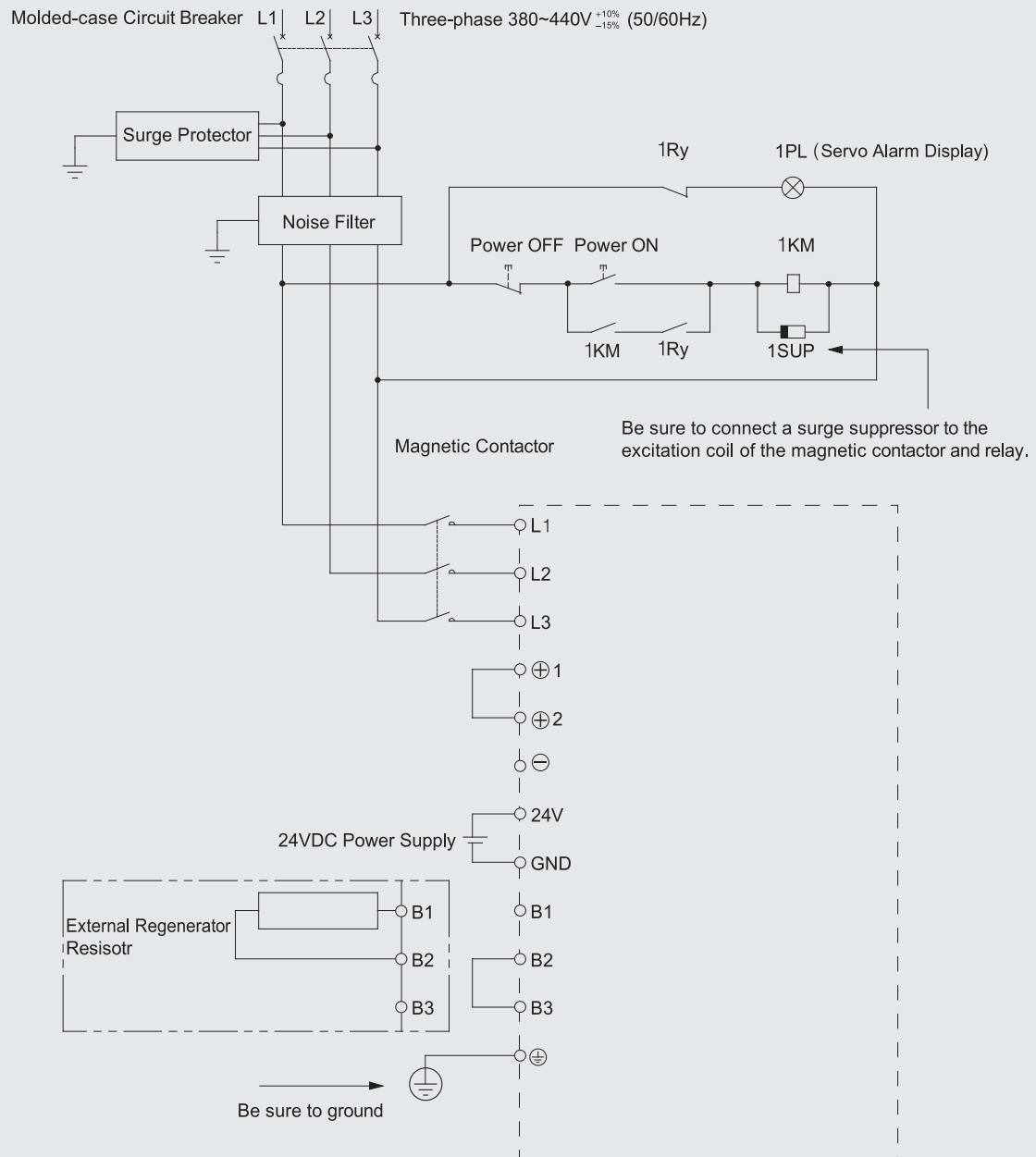

ProNet-□□□MG Control Circuit Wiring

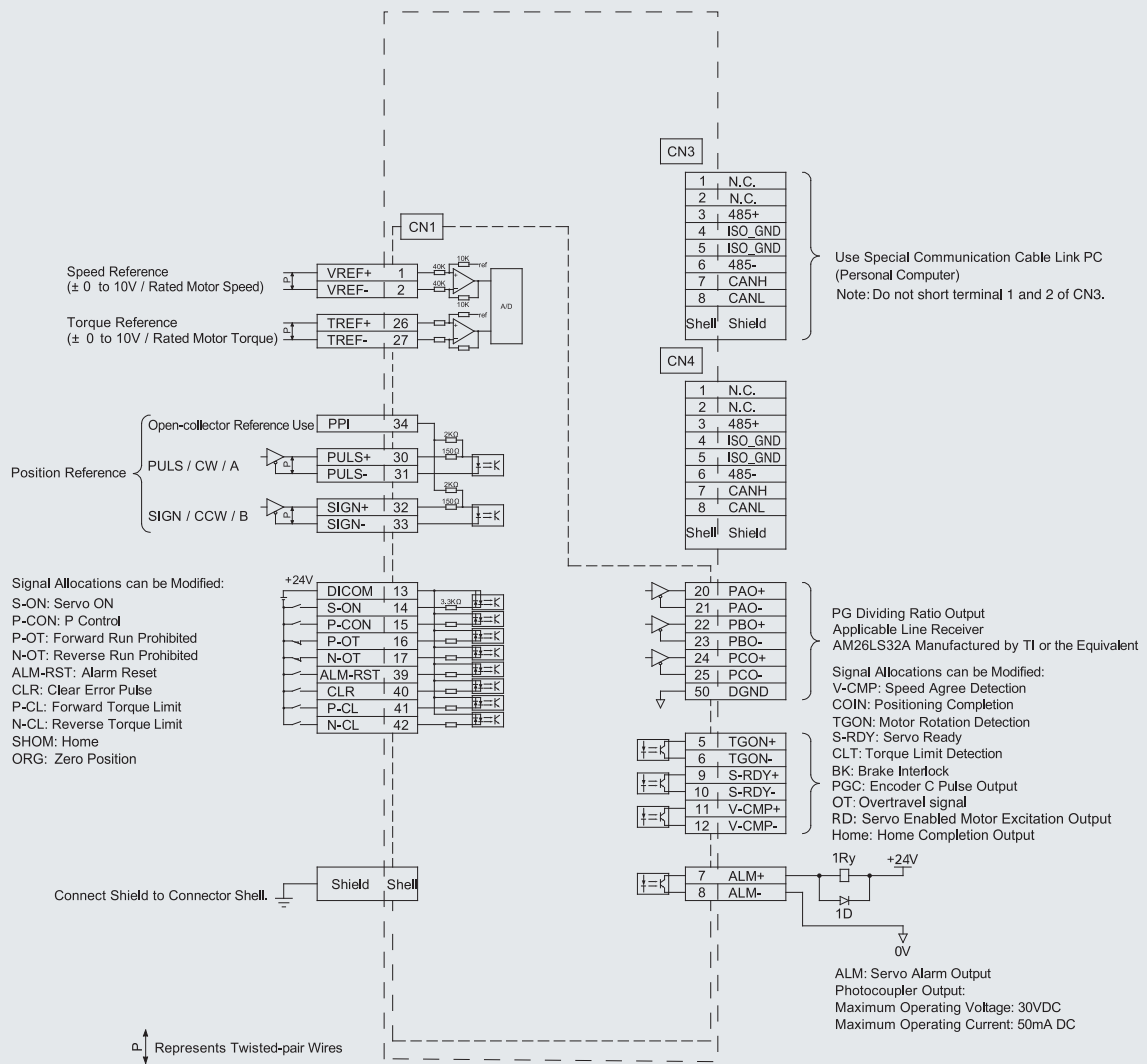

ProNet-□□□EG-EC Control Circuit Wiring

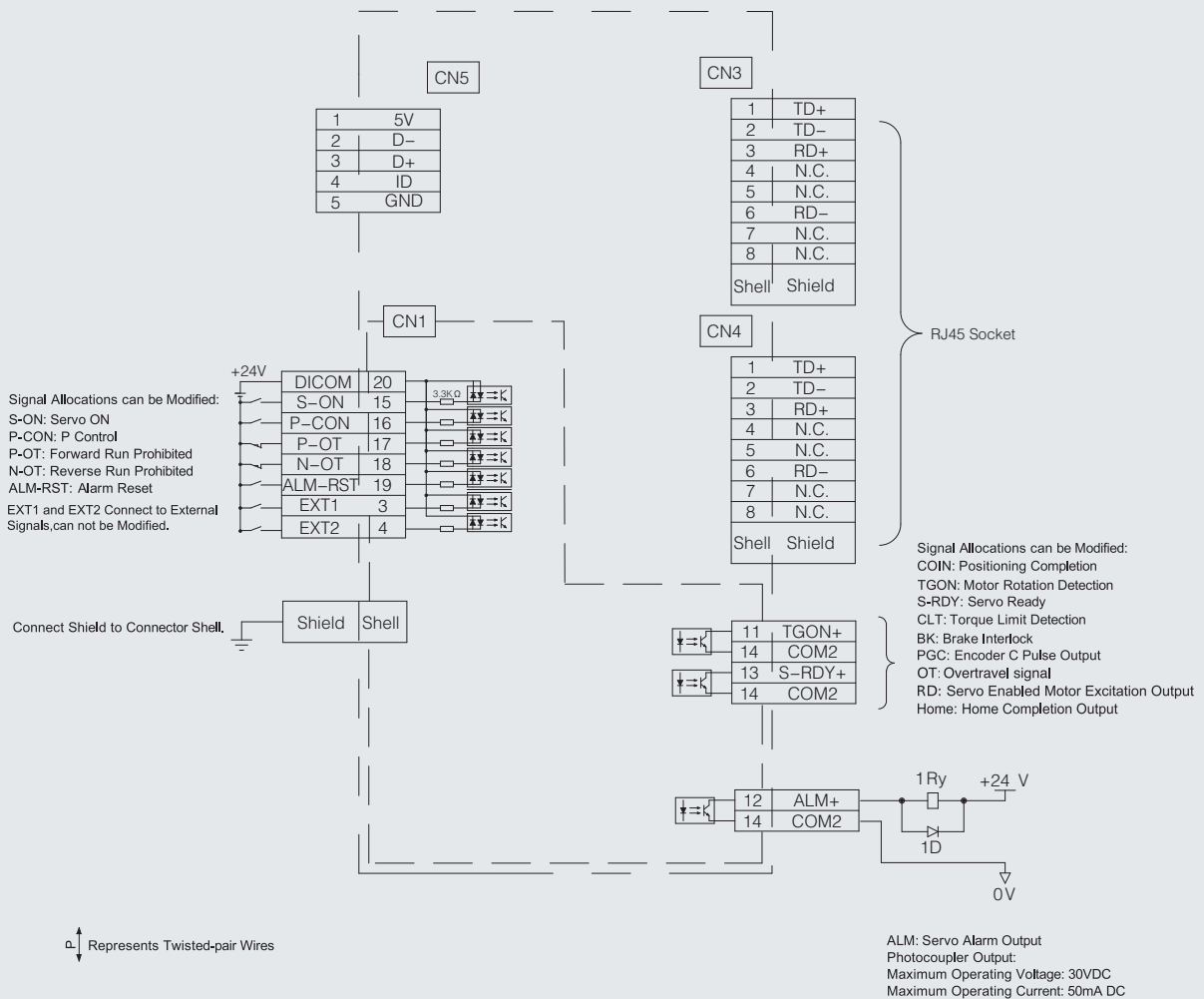

Dimension

Servo Drive

EMJ Dimension

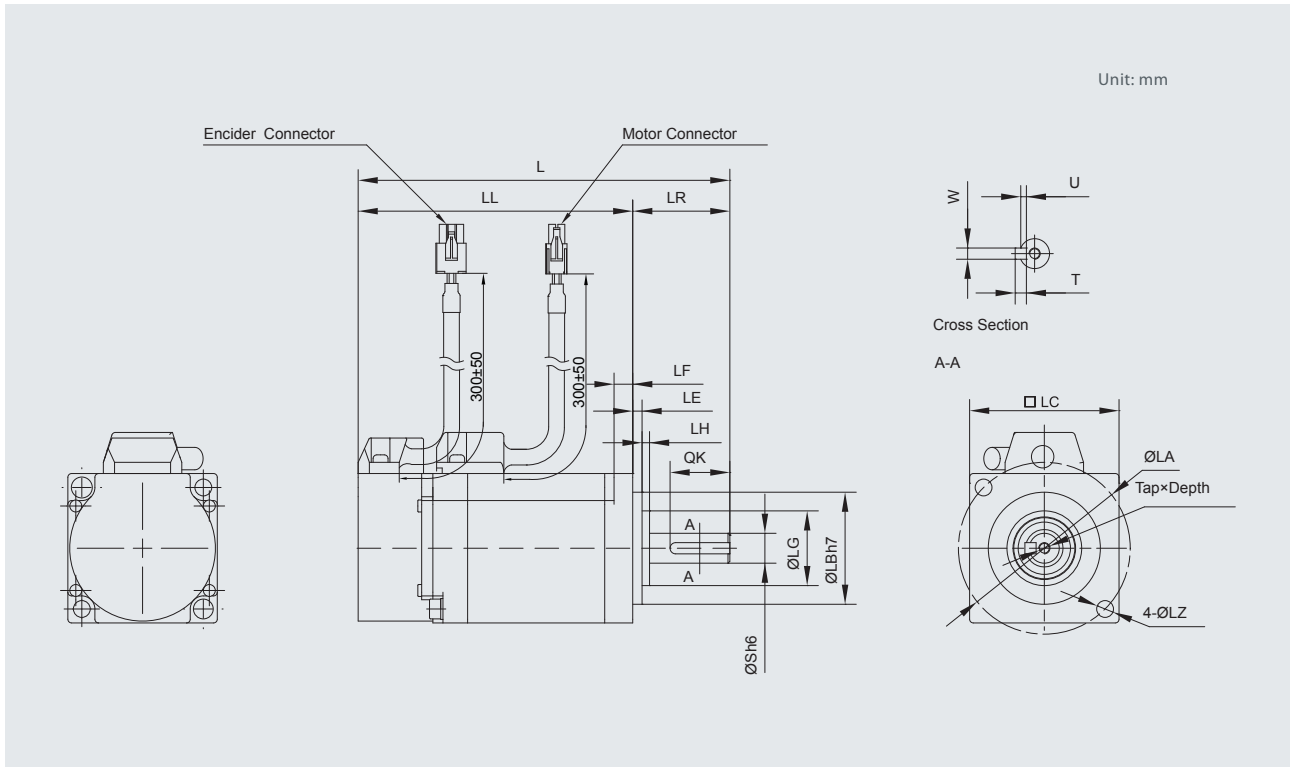

Model EMJ-	L	LL	Dimension									S	Tap×Depth	Key			
			LR	LH	LG	LE	LF	LC	LA	LB	LZ			QK	W	T	U
A5ASA	84.5(120.1)	59.5(95.1)	25	2	20	2.5	5	40	46	30	4.5	8	M3×10L	16	3	3	1.8
01ASA	98.5(134.1)	73.5(109.1)	25	2	20	2.5	5	40	46	30	4.5	8	M3×10L	16	3	3	1.8

Note: The dimension in parentheses are for servo motors with holding brakes.

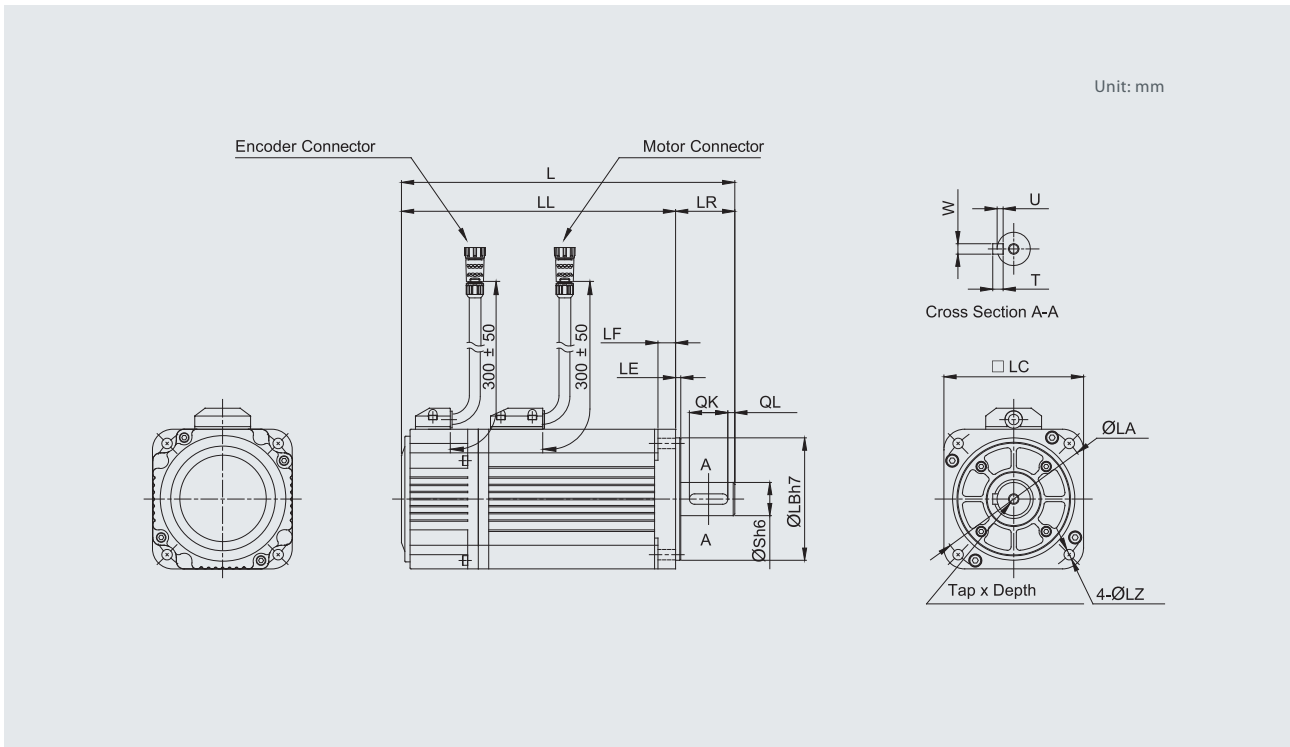

Model EMJ-	L	LL	Dimension							S	Tap×Depth	Key				
			LR	LE	LF	LC	LA	LB	LZ			QK	QL	W	T	U
02ASA	154(194)	124(164)	30	3	6	60	70	50	5.5	14	M5×10L	16	4	5	5	3
02AFA	142(182)	112(152)														
04AFB	161(201)	131(171)														
04ASA	174(214)	144(184)														
04AFH	172(212)	142(182)														
04ASH	182(222)	152(192)	35	9	80	90	70	7	19	M6×15L	22	6	6	3.5		
08AFB	173(216)	138(181)														
08ASB	186(229)	151(194)														
10AFB	191(234)	156(199)														
10ASB	204(247)	169(212)														

Note: The dimension in parentheses are for servo motors with holding brakes.

EMG Dimension

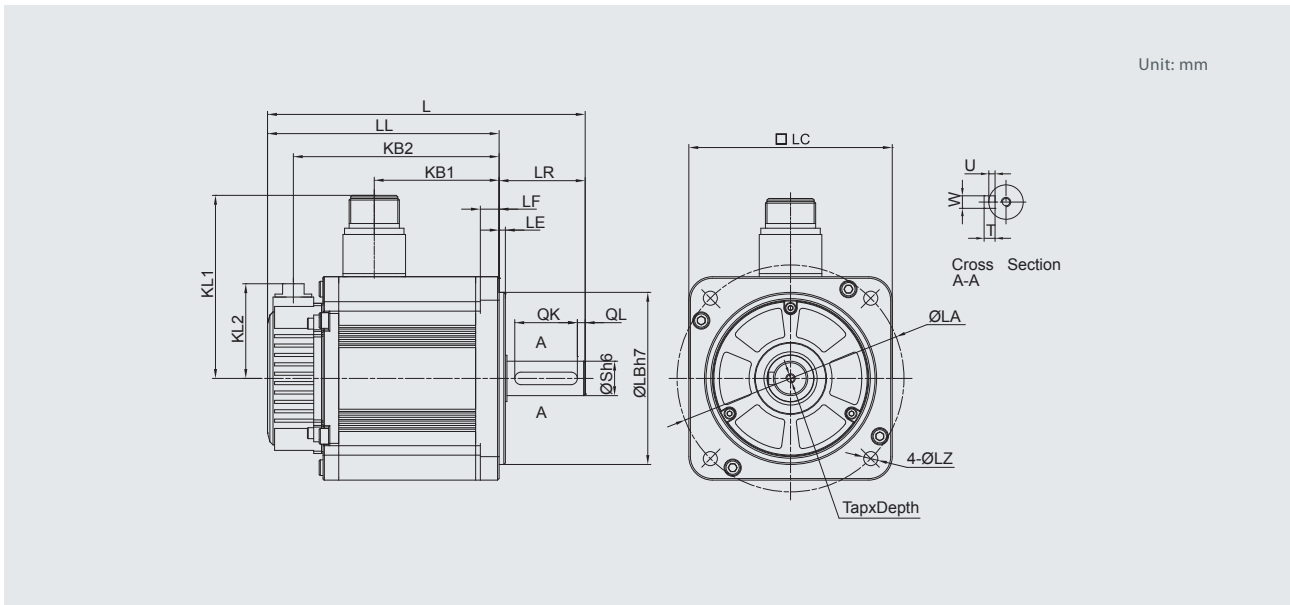

Model EMG-	L	LL	KB1	KB2	KL1	KL2	Dimension							S	Tap x Depth	Key				
							LR	LE	LF	LC	LA	LB	LZ			QK	QL	W	T	U
10□□B	203(245.5)	148(190.5)	80(103.2)	131.5(174)	117	60.5	55	4	12	130	145	110	9	22	M6×20L	40	5	8	7	4
15□□B	225(267.5)	170(212.5)	102(125.2)	153.5(196)	117	60.5	55	4	12	130	145	110	9	22	M6×20L	40	5	8	7	4
20□□B	247(289.5)	192(234.5)	124(147.2)	175.5(218)	117	60.5	55	4	12	130	145	110	9	22	M6×20L	40	5	8	7	4

Note: The dimension in parentheses are for servo motors with holding brakes.

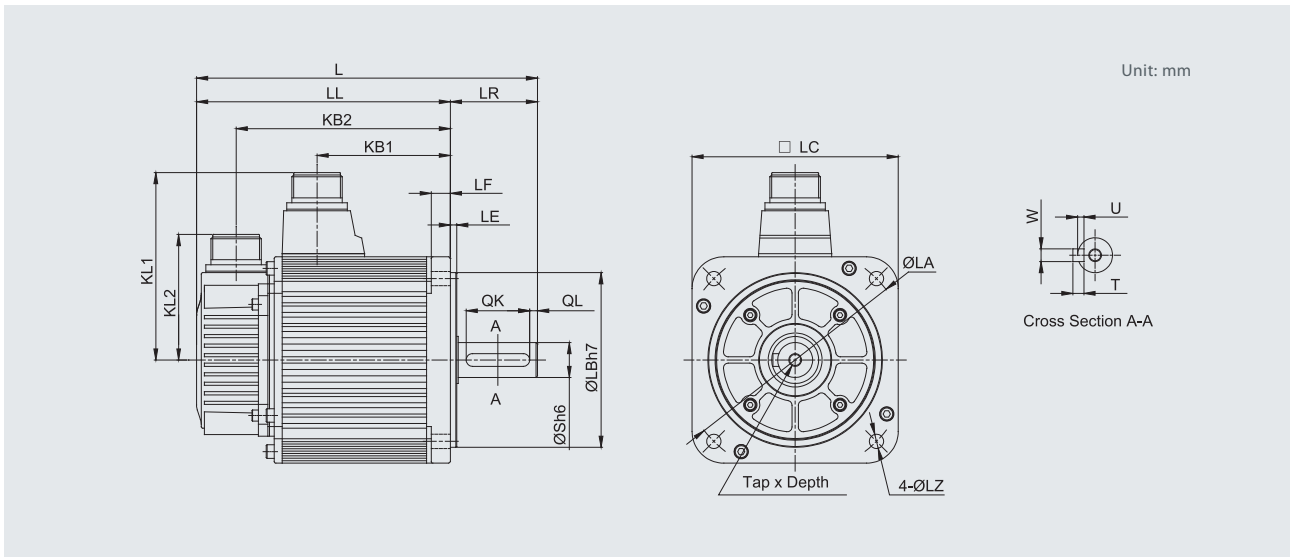

Model EMG-	L	LL	KB1	KB2	KL1	KL2	Dimension							S	Tap x Depth	Key				
							LR	LE	LF	LC	LA	LB	LZ			QK	QL	W	T	U
30□□A	307(378)	228(299)	143	203(274)	140	79	79	3.2	18	180	200	114.3	13.5	35	M8×16L	55	6	10	8	5
50□□A	357(428)	278(349)	183	253(324)	140	79	79	3.2	18	180	200	114.3	13.5	35	M8×16L	55	6	10	8	5

Note: The dimension in parentheses are for servo motors with holding brakes.

EML Dimension

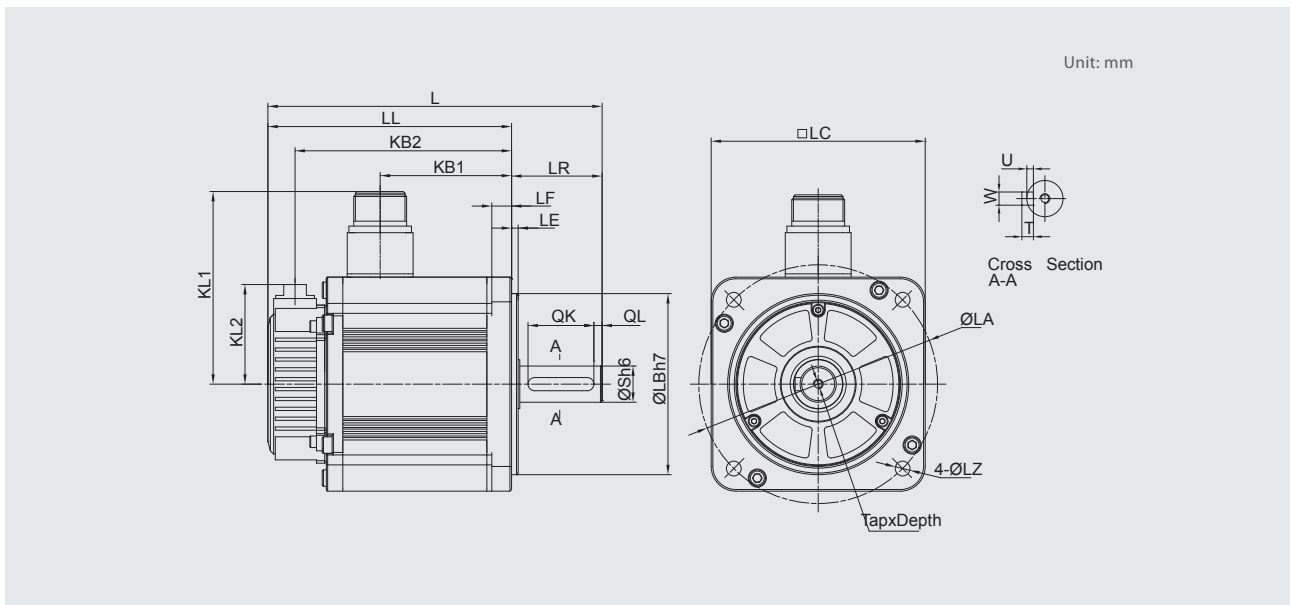

Model EML-	L	LL	KB1	KB2	KL1	KL2	Flange side							S	Tap x Depth	Key				
							LR	LE	LF	LC	LA	LB	LZ			QK	QL	W	T	U
10□□B	247(289.5)	192(234.5)	124(147.2)	175.5(218)	117	60.5	55	4	12	130	145	110	9	22	M6x20L	40	5	8	7	4

Note: The dimension in parentheses are for servo motors with holding brakes.

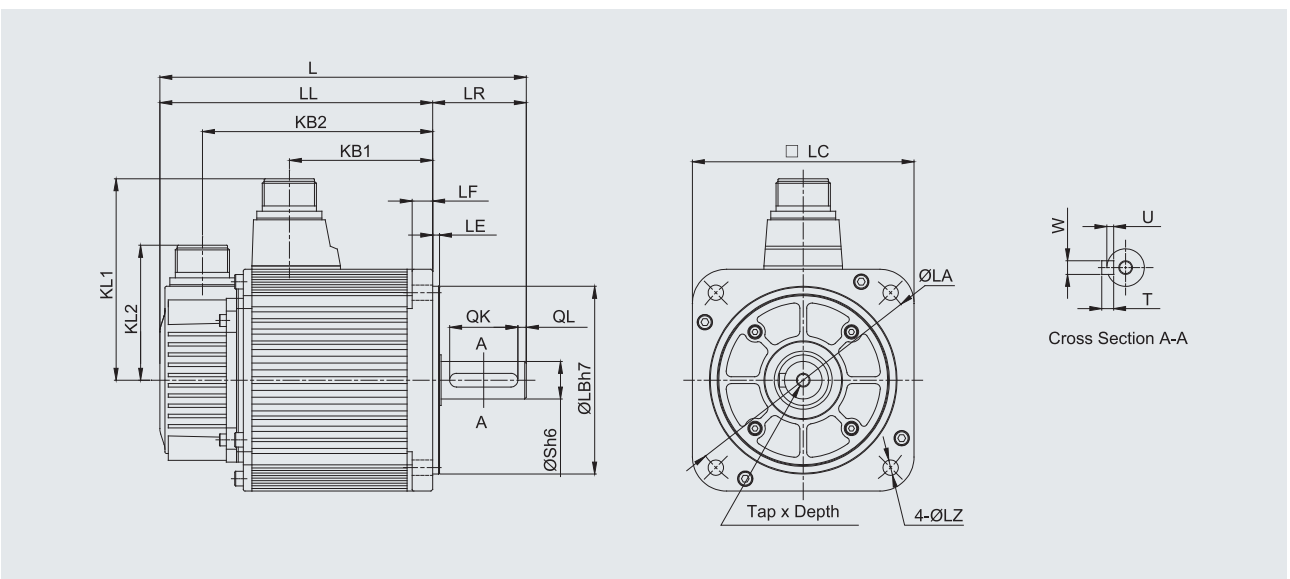

Model EML-	L	LL	KB1	KB2	KL1	KL2	Flange side							S	Tap x Depth	Key				
							LR	LE	LF	LC	LA	LB	LZ			QK	QL	W	T	U
20□□A	332(401)	253(322)	168	228(245)	140	79	79	3.2	18	180	200	114.3	13.5	35	M8x16L	55	6	10	8	5
30□□A	372(443)	293(364)	208	268(287)	140	79	79	3.2	18	180	200	114.3	13.5	35	M8x16L	55	6	10	8	5
40□□A	412(478)	333(399)	243	308(322)	140	79	79	3.2	18	180	200	114.3	13.5	35	M8x16L	55	6	10	8	5

Note: The dimension in parentheses are for servo motors with holding brakes.

Servo Drive

ProNet-A5A/01A/02A/04A

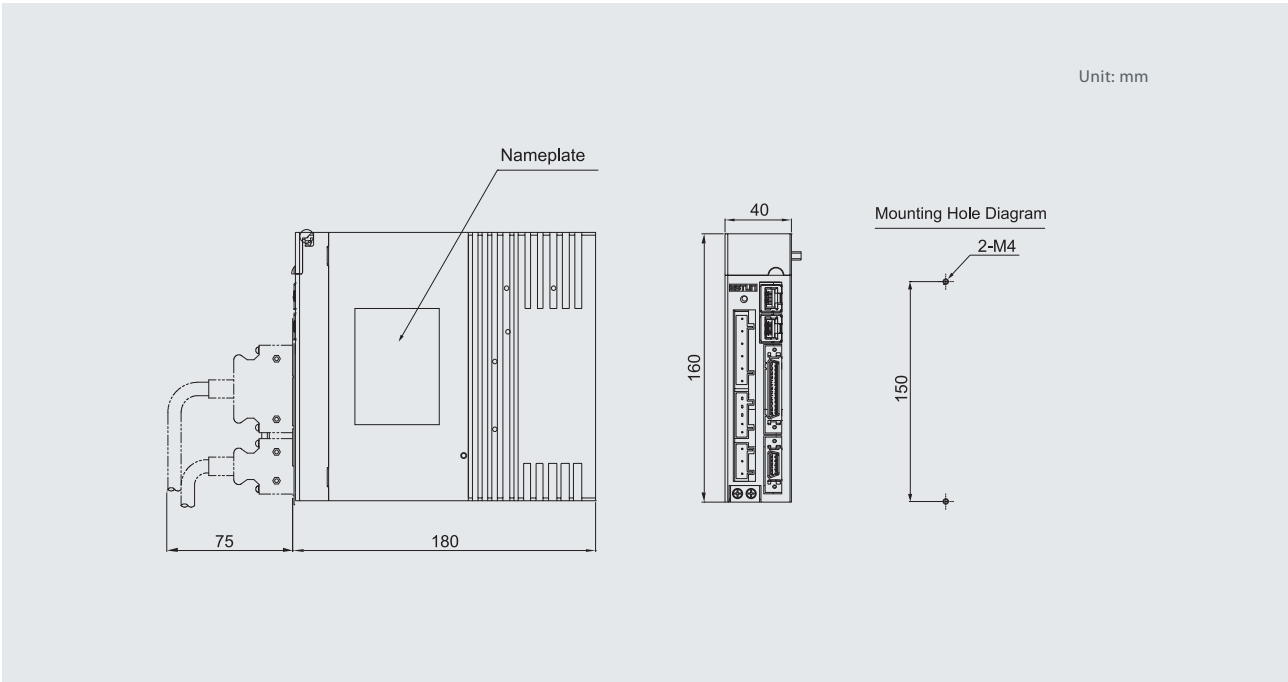

ProNet-08A/10A

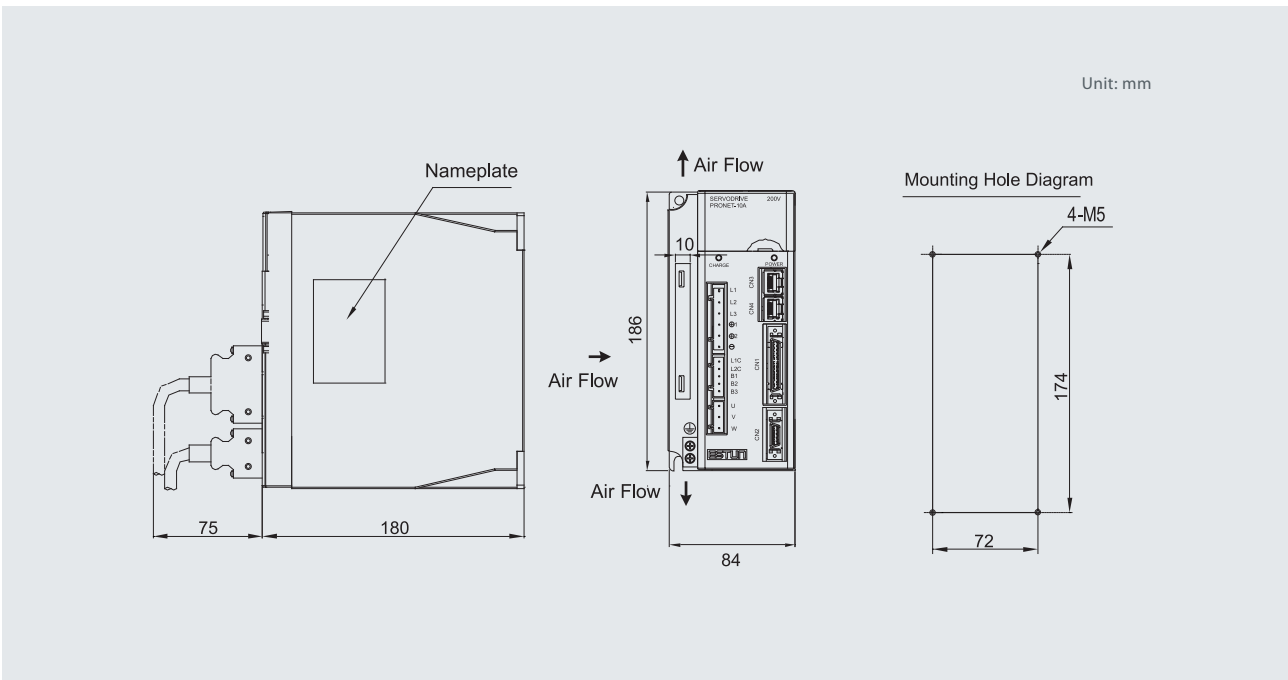

ProNet-10D/15A/15D/20A/20D

Unit: mm

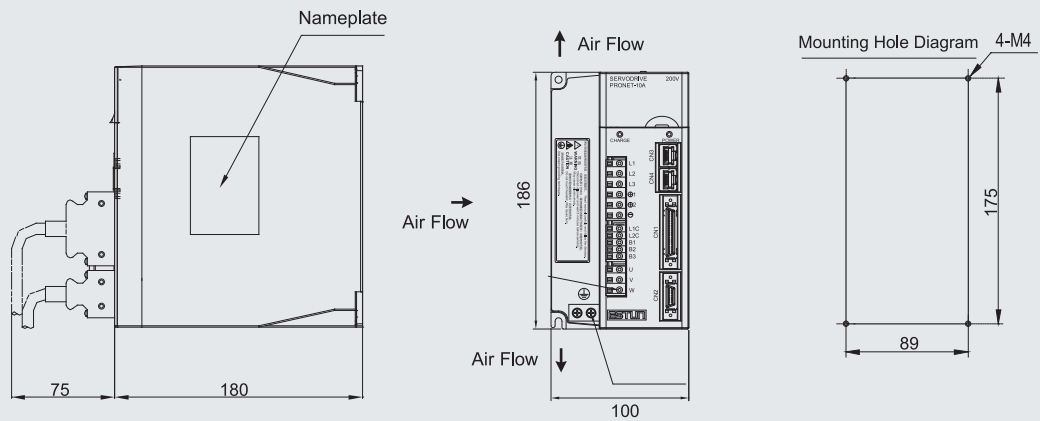

ProNet-30A/30D/50A/50D

Unit: mm

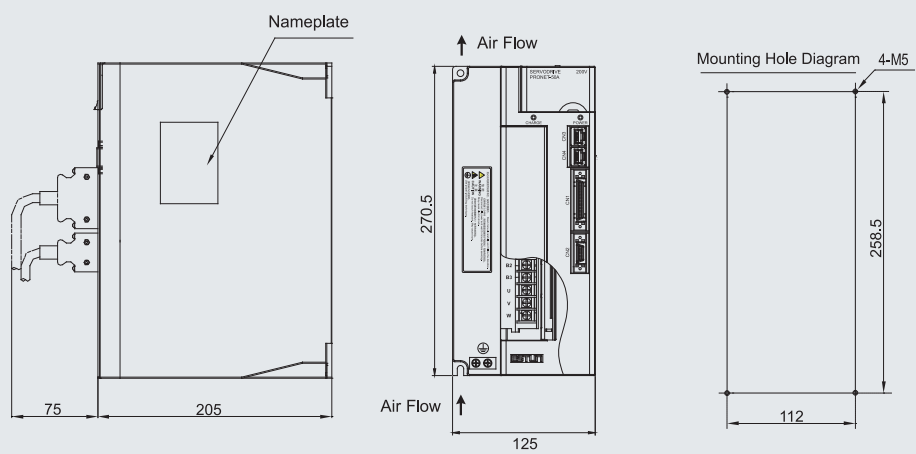

Cable

Encoder Cable

PDP-JB24-XX

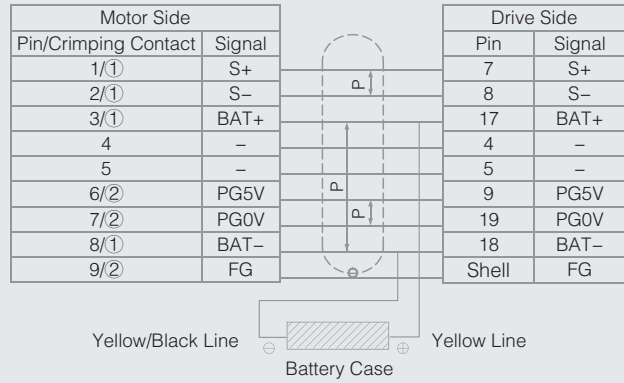
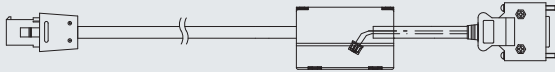

Motor Side Connector		Cable Dimension
Crimping Shell(Receptacle)	172161-1	-
Crimping Contact(Hole)①	170361-3	26-22AWG
Crimping Contact(Hole)②	170362-1	22-18AWG
A View From Pins Press-in Side		

Drive Side Connector	
Plug	10120-3000PE
Plug Shell	10320-52A0-008
Rubber Ring	Diameter 9 Receptacle Outlet Rubber Ring (3M/TE 20Pin Line)
A View From Soldering Side	

PSP-JB24-XX

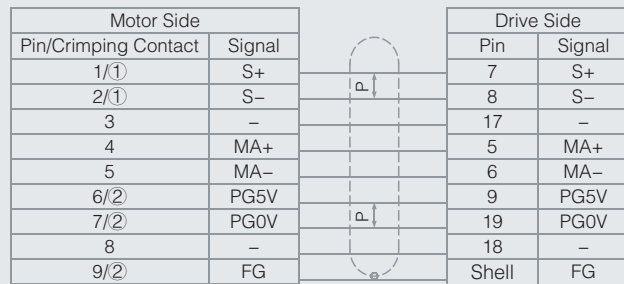
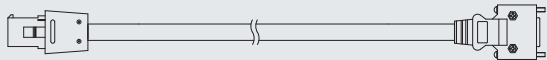

Motor Side Connector		Cable Dimension
Crimping Shell(Receptacle)	172161-1	-
Crimping Contact(Hole)①	170361-3	26-22AWG
Crimping Contact(Hole)②	170362-1	22-18AWG
A View From Pins Press-in Side		

Drive Side Connector	
Plug	10120-3000PE
Plug Shell	10320-52A0-008
Rubber Ring	Diameter 9 Receptacle Outlet Rubber Ring (3M/TE 20Pin Line)
A View From Soldering Side	

PDP-JE24-XX

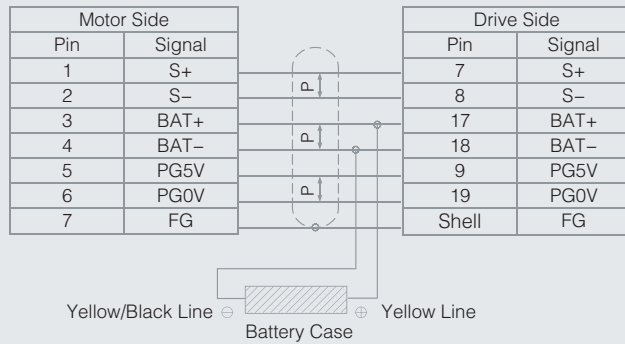
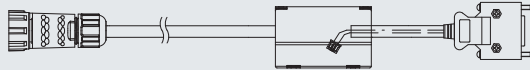

Motor Side Connector

Plug(Hole) CGRSD-7BMFA-SL8001

A View From Plug-in Side

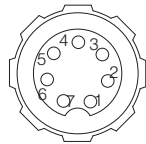

Drive Side Connector

Plug 10120-3000PE

Plug Shell 10320-52A0-008

Rubber Ring Diameter 9 Receptacle Outlet Rubber Ring (3M/TE 20Pin Line)

A View From Soldering Side

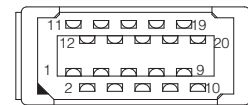

PBP-JE24-XX

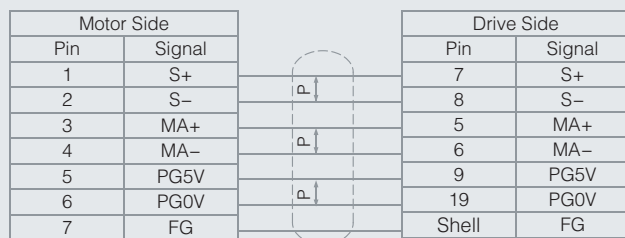

Motor Side Connector

Plug(Hole) CGRSD-7BMFA-SL8001

A View From Plug-in Side



Drive Side Connector

Plug 10120-3000PE

Plug Shell 10320-52A0-008

Rubber Ring Diameter 9 Receptacle Outlet Rubber Ring (3M/TE 20Pin Line)

A View From Soldering Side

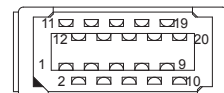

PDP-GA24-XX- II

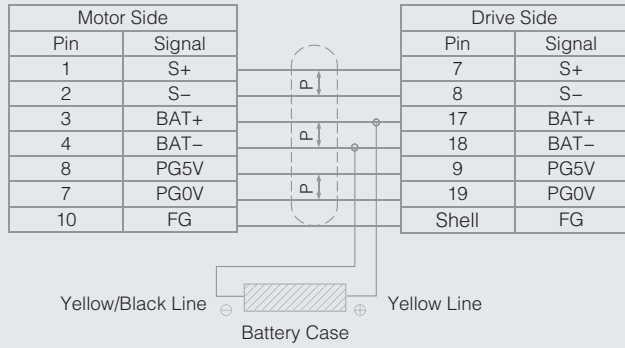

Motor Side Connector

Plug SC-CMV1-AP10S-C

A View From Pins Press-in Side

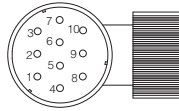

Drive Side Connector

Plug 10120-3000PE

Plug Shell 10320-52A0-008

Rubber Ring Diameter 9 Receptacle Outlet Rubber Ring (3M/TE 20Pin Line)

A View From Soldering Side

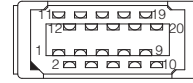

PSP-GA24-XX- II

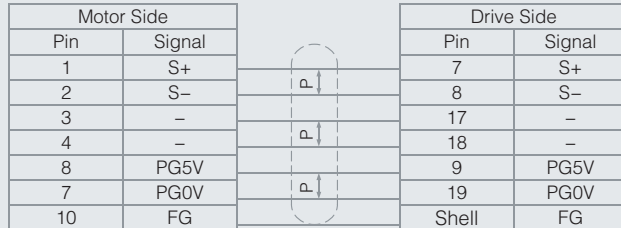
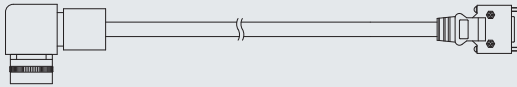

Motor Side Connector

Plug SC-CMV1-AP10S-C

A View From Pins Press-in Side

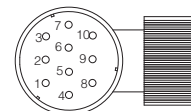

Drive Side Connector

Plug 10120-3000PE

Plug Shell 10320-52A0-008

Rubber Ring Diameter 9 Receptacle Outlet Rubber Ring (3M/TE 20Pin Line)

A View From Soldering Side

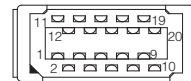

PDP-GA24-XX

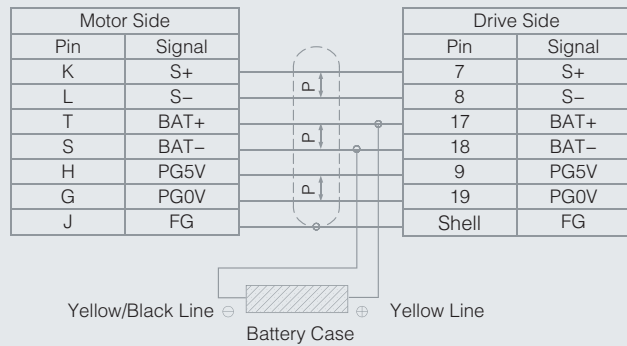
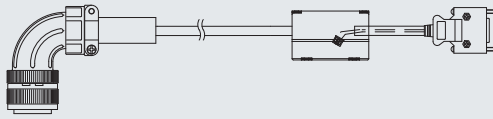

Motor Side Connector

Plug HMS3108B20-29S

A View From Pins Press-in Side

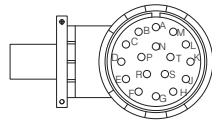

Drive Side Connector

Plug 10120-3000PE
Plug Shell 10320-52A0-008
Rubber Ring Diameter 9 Receptacle Outlet Rubber Ring (3M/TE 20Pin Line)

A View From Soldering Side

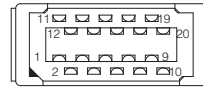

PSP-GA24-XX

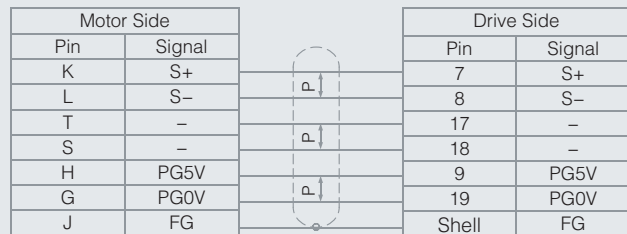
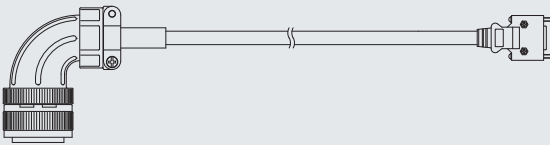

电机侧连接器

Plug HMS3108B20-29S

A View From Pins Press-in Side

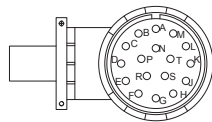

伺服驱动器侧连接器

Plug 10120-3000PE
Plug Shell 10320-52A0-008
Rubber Ring Diameter 9 Receptacle Outlet Rubber Ring (3M/TE 20Pin Line)

A View From Soldering Side

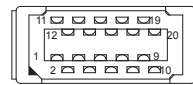

Power Cable

PDM-JB18-XX

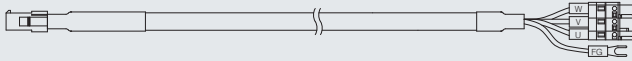

Motor Side		Drive Side	
Pin	Signal	Pin	Signal
1	U	1	U
2	V	2	V
3	W	3	W
4	FG	Crimping Terminal	FG

Motor Side Connector

Crimping Shell(Receptacle)	172159-1
Crimping Contact(Hole)	170362-1

A View From Pins Press-in Side

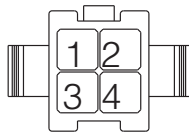

Drive Side Connector

Plug	8EDGKB-7.5-03P-11-06AH
Crimping Terminal	Fork Bare End, M4/SV1.5-4
Pin	VE-1.0

A View From Cable Outlet Side

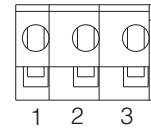

PDMB-JB18-XX

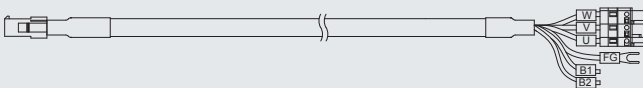

Motor Side		Drive Side	
Pin	Signal	Pin	Signal
1	U	1	U
2	V	2	V
3	W	3	W
4	FG	Crimping Terminal	FG
5	B1	5	B1
6	B2	6	B2

Motor Side Connector

Crimping Shell(Receptacle)	172160-1
Crimping Contact(Hole)	170362-1

A View From Pins Press-in Side

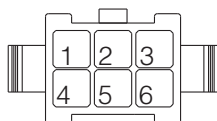

Drive Side Connector

Plug	8EDGKB-7.5-03P-11-01AH
Crimping Terminal	Fork Bare End, M4/SV1.5-4
Pin	VE-1.0

A View From Cable Outlet Side

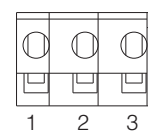

PDM-GA14-XX- II

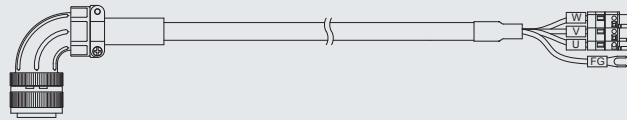

Motor Side		Drive Side	
Pin	Signal	Pin	Signal
B	U	1	U
I	V	2	V
F	W	3	W
C	FG	Crimping Terminal	FG
D	FG		

Shorted; Wire BVR1.5mm²

Drive Side Connector

Plug	HMS3108AE20-18S
A View From Pins Press-in Side	

Drive Side Connector

Plug	8EDGKB-7.5-03P-11-06AH
Crimping Terminal	Fork Bare End, M4/SV2-4
A View From Cable Outlet Side	

PDMB-GA14-XX- II

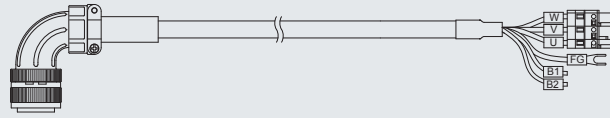

Motor Side		Drive Side	
Pin	Signal	Pin	Signal
B	U	1	U
I	V	2	V
F	W	3	W
C	FG	Crimping Terminal	FG
D	FG		
G	B1		B1
H	B2		B2

Shorted, Wire BVR1.5mm²

Motor Side Connector

Plug	HMS3108AE20-18S
A View From Pins Press-in Side	

Drive Side Connector

Plug	8EDGKB-7.5-03P-11-06AH
Crimping Terminal	Fork Bare End, M4/SV2-4
A View From Cable Outlet Side	

PDM-JE18-XX

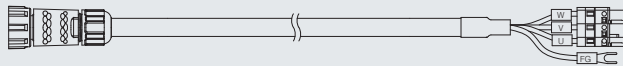

Motor Side		Drive Side	
Pin	Signal	Pin	Signal
1	U	1	U
2	V	2	V
3	W	3	W
4	FG	Crimping Terminal	FG

Motor Side Connector	
Crimping Contact(Hole)	CGRSB-4BMFA-SL8001
A View From Pins Press-in Side	

Drive Side Connector	
Plug	8EDGKB-7.5-03P-11-01AH
Crimping Terminal	Fork Bare End, M4/SV1.5-4
Pin	VE-1.0
A View From Cable Outlet Side	

PDM-GD12-XX

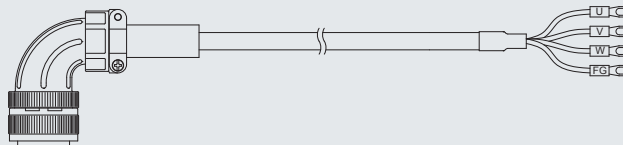

Motor Side		Drive Side	
Pin	Signal	Pin	Signal
A	U	Crimping Terminal	U
B	V	Crimping Terminal	V
C	W	Crimping Terminal	W
D	FG	Crimping Terminal	FG

Motor Side Connector	
Plug	HMS3108B22-22S
A View From Pins Press-in Side	

Drive Side Connector	
Crimping Terminal	Fork Bare End, M4/SV2-4

Brake Cable

PBK-JE18-XX

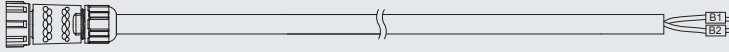

Motor Side		Drive Side	
Pin	Signal	Signal	
1	B1	B1	
2	B2	B2	

Motor Side Connector

Crimping
Contact(Hole)

CGRSB-2BMFA-SL8001

A View From
Pins Press-in
Side

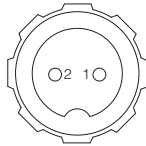

Connection Cable

EtherCAT Connection Cable PSC-DR0A-0M3



ESView Debugging Cable USB-RS485 (RJ45)



ESView Debugging Cable (EtherCAT) MINI USB-Double Magnetic Ring Shield-1M5



Battery Case

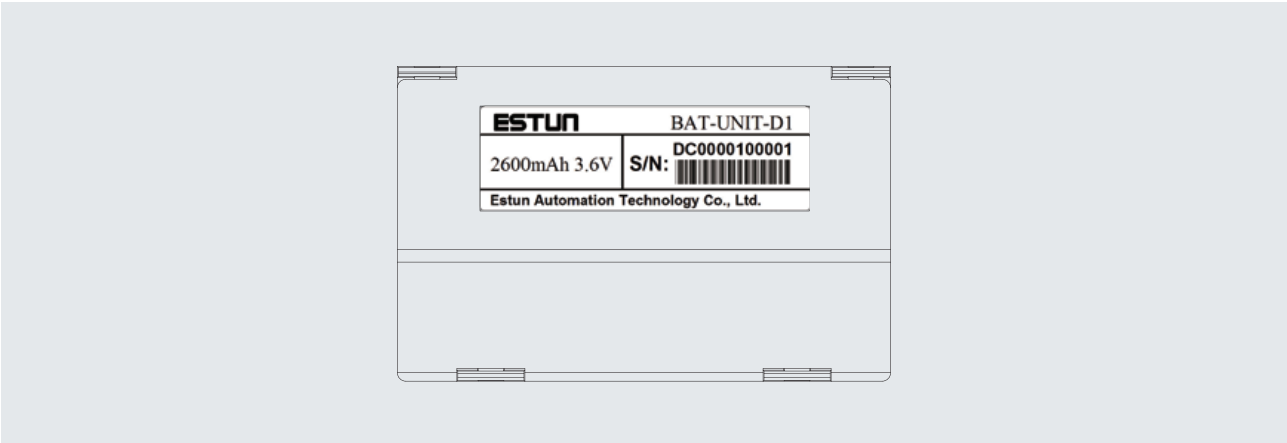

Battery Case Accessory		
Name	Model	Number
Battery Case	BAT-UNIT-D1	1
Cable Clamp	BAT-UNITD1-03	1
Cross Recessed Pan Head Tapping Screw	GB845-85 M2.9*6	1

- Notes:
- ① BAT-UNIT-D1 is the updated battery case of Bat-Unit-A1.If Bat-Unit-A1 is under voltage, please purchase the materials of Battery Case Accessory instead of it.
 - ② If BAT-UNIT-D1 is under voltage, please purchase lithium battery LS14500 [with lead and plug] instead of it.
 - ③ Purchase other alternates of Battery Case Accessory, please consult customer service staff.

Terminal Resistor Suite

485-HRS-120R (RS485)

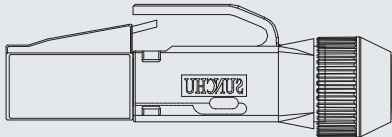

Drive Side Connector		
Pin	Signal	
3	485+	R
6	485-	

CAN-HRS-120R (CANOpen)

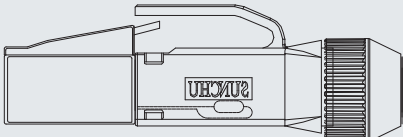

Drive Side Connector		
Pin	Signal	
7	CANH	R
8	CANL	

20/50 PIN Connecting Suite

20PIN Connecting Suite

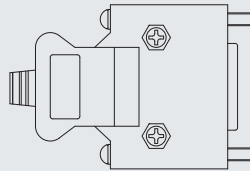

20PIN Connecting Suite

Plug	10120-3000PE
Plug Shell	10320-52A0-008
A View From Soldering Side	

50PIN Connecting Suite

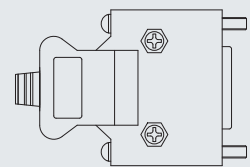

50PIN Connecting Suite

Plug	10150-3000PE
Plug Shell	10350-52A0-008
A View From Soldering Side	

Accessories

Selecting Peripheral Devices

Servo Drive (ProNet)	Main Circuit Voltage	Specifications for Internal Regenerative Resistor	Min.Allowable Resistance	Min. Rated Input Current for Three-phase Filters	Min. Rated Current for Circuit Breaker
ProNet-A5A	200-230VAC	—	25Ω	—	5A
ProNet-01A	200-230VAC	—	25Ω	—	5A
ProNet-02A	200-230VAC	—	25Ω	—	10A
ProNet-04A	200-230VAC	—	25Ω	—	10A
ProNet-08A	200-230VAC	50Ω/60W	25Ω	—	25A
ProNet-10A	200-230VAC	50Ω/60W	25Ω	—	25A
ProNet-15A	200-230VAC	40Ω/80W	25Ω	—	35A
ProNet-20A	200-230VAC	40Ω/80W	25Ω	—	55A
ProNet-30A	200-230VAC	10Ω/300W	10Ω	27A	70A
ProNet-50A	200-230VAC	10Ω/300W	10Ω	42A	100A
ProNet-10D	380-440VAC	200Ω/80W	50Ω	—	12A
ProNet-15D	380-440VAC	200Ω/80W	50Ω	—	20A
ProNet-20D	380-440VAC	200Ω/80W	40Ω	—	24A
ProNet-30D	380-440VAC	40Ω/300W	35Ω	14A	33A
ProNet-50D	380-440VAC	40Ω/300W	20Ω	23A	55A



ESTUN
Drive Your Success!

Mission —We are offering reliability, accuracy and efficiency!

Vision —Enjoy your life from Automation!

Values —Focus, Integrity, Growing together!

pamoco[®]

PAMOCO S.p.A.
Via Riccardo Lombardi,
19/6 - 20153, Milano

Tel: (+39) 02 3456091
Fax: (+39) 02 33104342
e-mail: info@pamoco.it
www.pamoco.it